

Transfer Belt

Fast, easy and safe unloading



Faster unloading

- Transfer Belt allows for a more productive and faster unloading process
- Improved utilization of existing installations
- Faster baggage handling in peak periods ensuring on-time performance
- One operator can handle a large number of items in an efficient and ergonomically correct manner



Fewer injuries

- Eliminates heavy lifting and twisting movements to minimise manual handling risks
- Minimises physical exertion and reduces risk of injuries to baggage handlers
- Reduces risk of back and shoulder injuries resulting in less sick leave
- Can be operated from both sides



Less damaged baggage

- Enables a gentler baggage handling as bags are transferred from the cart to the baggage conveyor
- Less damage to baggage leading to reduced costs and more satisfied passengers
- Handles a wide variety of passenger baggage and packages



Seamless integration

- Can be used with various types of containers and baggage carts
- Easy integration into existing conveyor systems
- Can be easily moved along the conveyor line to preferred position
- Compact and space-saving design

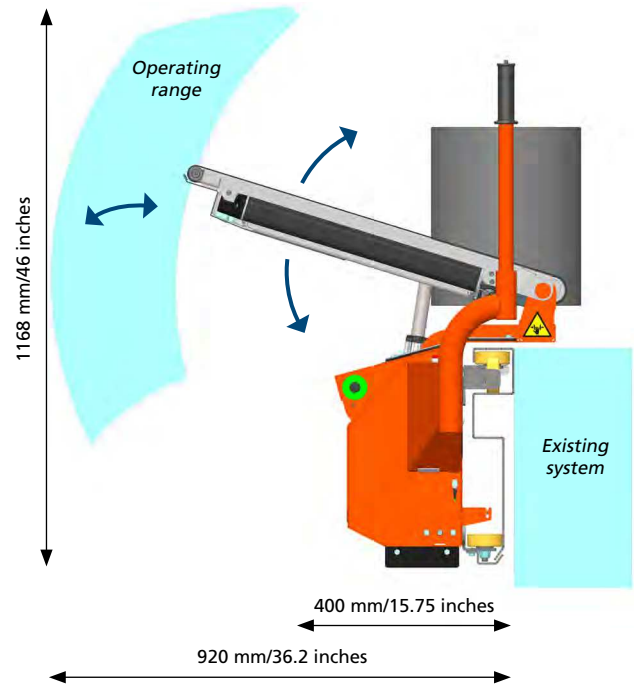
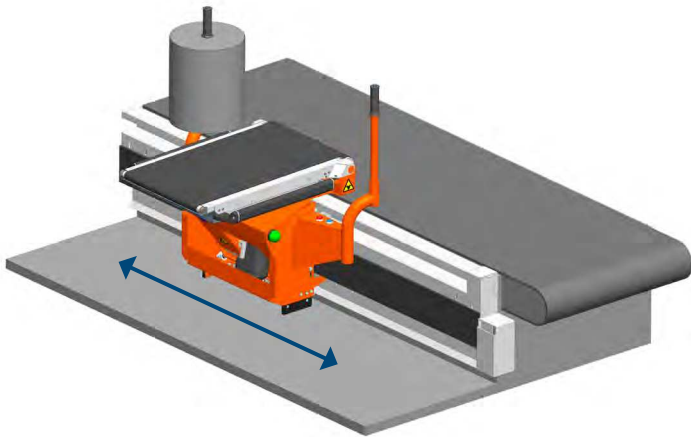

Specifications

Belt width:	440 mm/17 inches
Operating voltage:	24 VDC
Supply voltage:	110-250VAC (50/60Hz) or 380-480VAC (50/60Hz)
Compatibility:	Simple integration and minimum requirements for existing systems
Standard features:	<ul style="list-style-type: none"> Powered horizontal and vertical movements Motorized belt Modular rail system in specified length Automatically returns to stowed position when deactivated Space required in stowed position: 400 mm/15.75 inches Floor-mounted Multi-purpose handle for intuitive control

Contact

Power Stow A/S
 Erhvervsparken 7
 DK-4621 Gadstrup
 Denmark
 Phone: +45 4631 1032
 Fax: +45 4631 0152
 info@powerstow.com

Power Stow Americas Inc.
 6175 Northbelt Parkway,
 Suite C
 Norcross, GA 30071
 USA
 Phone: +1 404 242 1717
 info-us@powerstow.com

Power Stow Asia Pacific
 Room 719, 228 Meiyuan Road
 Enterprise Plaza,
 Jingan District
 Shanghai 200070
 China
 Phone: +86 139 1737 9084
 info-asia@powerstow.com



www.powerstow.com

Power Stow® Transfer Belt is protected by the following patent number:
 WO/2018/083641 (Conveyor system)